

## Cim 7860T

### BALANCING VALVE - VARIABLE ORIFICE - PN 25



This article was made in compliance with the quality management requirements of ISO 9001 standard. All articles are tested according to the EN 12266-1 standard.

It can be used in a wide variety of sectors: heating, air conditioning, water, sanitary systems and generally with any non corrosive liquid.

It is guaranteed for 5 years.

It is made of a brass alloy that complies with standard EN 12165-CW617N-DW.

Nominal Pressure: PN25

Operating temperature: -10 to 120°C

### FLOW AND PRESSURE DROP

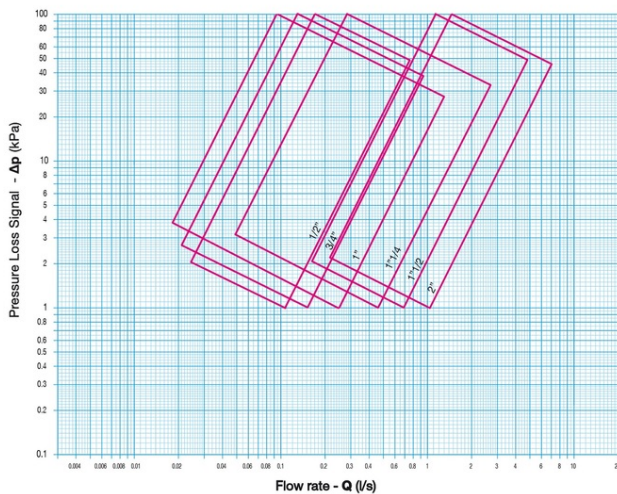

Notes:  
 1 l/s = 3.6 m<sup>3</sup>/h  
 1 m<sup>3</sup>/h = 0.278 l/s  
 1 kPa = approx. 100 mm  
 1 bar = 100 kPa

### PRESSURE TEMPERATURE RATINGS

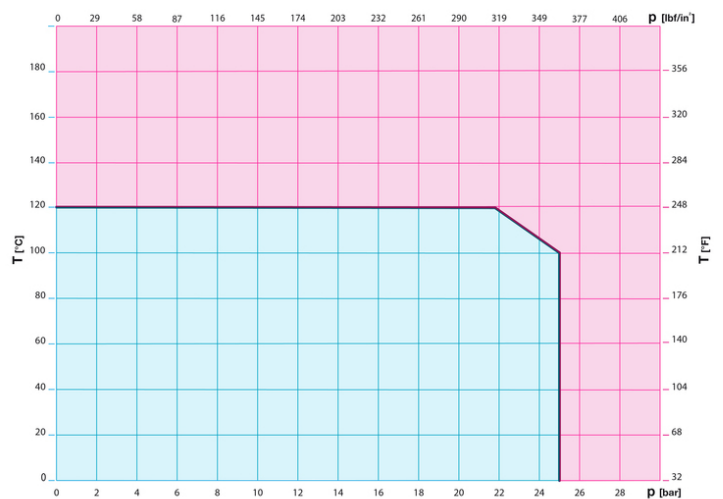

Notes:  
 1 bar = 14,5 psi  
 1 bar = 14,5 lbf/in<sup>2</sup>  
 °C = 5/9 x (°F-32)  
 °F = 32 + (9/5 x °C)

## TECHNICAL DRAWING

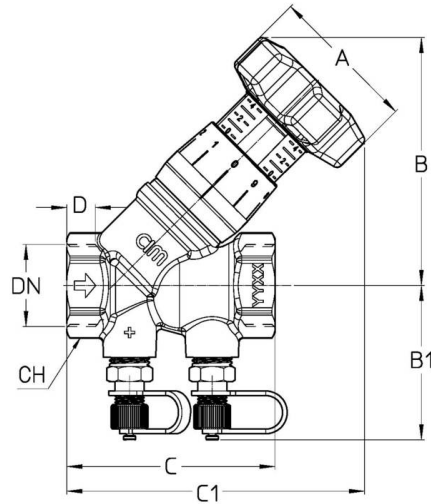

DN	1/2"	3/4"	1"	1"1/4	1"1/2	2"
<b>Grms.</b>	<b>380</b>	<b>430</b>	<b>535</b>	<b>840</b>	<b>1400</b>	<b>1645</b>
A	50	50	50	50	50	50
B	83	81	83	87	107	104,5
B1	53,5	57,5	59,5	65	64	70
C	59	68	85	109	123	141
C1	92	96	115	118	134	146
D	12,5	12,5	14,5	16	16	19
CH	25	31	38	47	55	66

Thread:  
ISO 228

## TECHNICAL CHARACTERISTICS

### KV - KVS

DN	1/2"	3/4"	1"	1"1/4	1"1/2	2"
KV - KVS	3,94	5,33	8,92	16,68	25,12	36,98

KV = Flow rate in m<sup>3</sup>/h at a pressure drop of 1 bar

KVS = Water flow rate that causes a pressure drop of 1 bar measured on the pressure connections

### REACH Regulation

According to article 33 of REACH Regulation, we inform you that the components made of bronze and brass alloys that are parts of the articles we supply, contain the lead (as alloy component) in a higher quantity of the limit of 0,1% in weight. Lead has been inserted in the list of SVHC substances nominated for the authorisation process, in the updating published by the European Chemical Agency ECHA on 27th June 2018. Lead has been introduced with the following information:

- Substance: Lead
- CAS: 7439-92-1
- EC: 231-100-4
- List: SVHC
- Data of Inclusion: 27<sup>th</sup> June 2018

Since lead is an element of the alloy, no exposure is expected and consequently, no further information is requested for the safe use of this product.

The list is available at the following link: <https://echa.europa.eu/it/candidate-list-table> and since it is a continuously updated list, we declare the constant monitoring about insertion of new substances and the prompt on time information to our customers in case such substances should be contained in the products we supply.

Make sure product materials and features are suitable for system scope and conform to the local regulations in force

# OUR CERTIFICATIONS

